

# UNWAVERING POWER ON THE MOVE

SPTO 1000 FORD F600 TRUCK MOUNTED CONCRETE PUMP



# ADVANCED ENGINEERING OUT PERFORMS THE COMPETITION



## INDUSTRY LEADING PUMPKIT

Symmetrical switching aids in pumping the harshest mixes by providing faster switching of the Rock Valve with five-inch outlet. This unique feature allows the concrete pump to provide smoother, quieter operation even at material pressures up to 1100 psi encountered on high-rise structures. The long stroke of the pumping cylinders allows the unit to operate at a low 35 strokes per minute for less wear.



## TOUGH AND COMPACT TRUCK

The ultimate on-the-go concrete solution. Mounting the powerful SCHWING SPTO 1000 on a Ford F600 means unparalleled access to any jobsite. Simplify your operation: eliminate the need for a CDL operator and a separate hose trailer. Efficiency delivered.



## EASE OF USE AND SERVICEABILITY

Operator friendly features include larger deck area, remote waterbox filling / draining and two large fold down sideboards for easier access to system. Frame mounted tool box and clamp basket provide additional storage.



## CONTROL AT YOUR FINGER TIPS

SchwingControl Technology (SCTII) enhance SPTO models by providing safe and easy operation of the concrete pump with valuable feedback of critical components. Information is available both in-cab and on the pump. An integrated back up camera is included, and both radio and cable remotes are standard equipment.

# SPECIFICATIONS

## SPTO 1000

	U.S.	Metric
Concrete Output Per Hour	70cu yds	54 cu m
Maximum Pressure on Concrete	1100 psi	76 bar
Maximum Aggregate Size	1.5 in	37 mm
Concrete Cylinder Diameter	7 in	180 mm
Concrete Cylinder Stroke Length	39 in	1000 mm
Differential Piston/Rod Diameter	3.54/ 1.96 in	90/ 50 mm
Outlet Diameter @ 8 Degree Angle	5 in	125 mm
Concrete Valve Type	Long Rock™	
Shifting Cylinders	2	
Max. Pump Strokes Per Minute	35	
Volume Control	0 to Maximum	
Hydraulic System	Open Loop	
Main Hydraulic Pump	A11VO130	
Hydraulic Pressure		
Hydraulic Tank Capacity	4350 psi	300 bar
Remote Control Cable	70 gal	265l
	100 ft	30.5 m

## FORD F600 4X4 XLT

Engine	6.7L Power Stroke V8
Horsepower	330 HP @ 2200 rpm
Transmission	TorqShift 10-Speed SelectShift Automatic
GVWR	22,000 lbs
Wet Weight	17,400 lbs
Cargo Capacity	4,560 lbs

## STANDARD FEATURES

90/50 x 1000:180 Pumpkit  
 Power- Gearbox "PTO"  
 Twin Circuit Hydraulics - Accumulator  
 Tool Box & Alignment Pins  
 Fuel Level Sensor  
 Low Hydraulic Oil Level Sensor  
 Aluminum Tool Box 36"  
 Clamp Basket 36"  
 Symmetrical Shifting  
 SCT2 Pump Controls w/ SCC In Cab Controls  
 Radio Remote Control - Scanreco  
 Open / Flat Decking w/ Sideboards and Steps  
 Backup Camera  
 Fold Down Hopper Cover  
 Remote Water Box Fill and Drain  
 Water Pump - Hydraulic Driven  
 Dual Stroke Counter  
 Ram Change Mode  
 Standard One-Color Paint (Schwing White)

## OPTIONAL FEATURES

Autogreaser - Rock Valve  
 Extended Life Wear Parts (CR & WP)  
 High Pressure Water Pump w/ Spray Wand  
 Hopper Grate - Round Bar (For Fiber)  
 On-board Filtration  
 Red Light / Green Light (Pump On / Off)  
 Vibrator 12v  
 Work Light - Hopper Cover Mount  
 Accumulator Bypass Kit  
 Water Tank Heater - Square Tank  
 Shotcrete Setup (150 Bar Soft Switch & 1.3mm Nozzles)  
 Hopper Cover - Aluminum Diamond Plate  
 Emergency Hose & Fittings Kit/v  
 Pipe Rack

# SPTO 1000 FORD F600

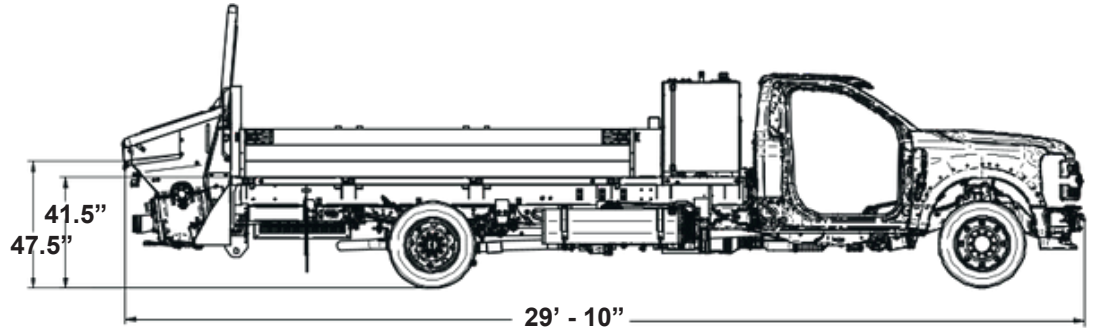
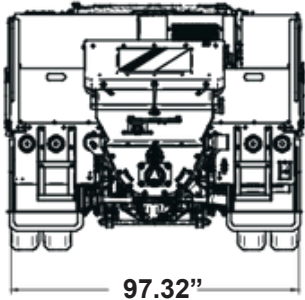

Hopper Height	47.5"
Deck Height	41.5"
Deck Length	12' 3"
Height	105"
Width	97.32"
Length	29' 10"

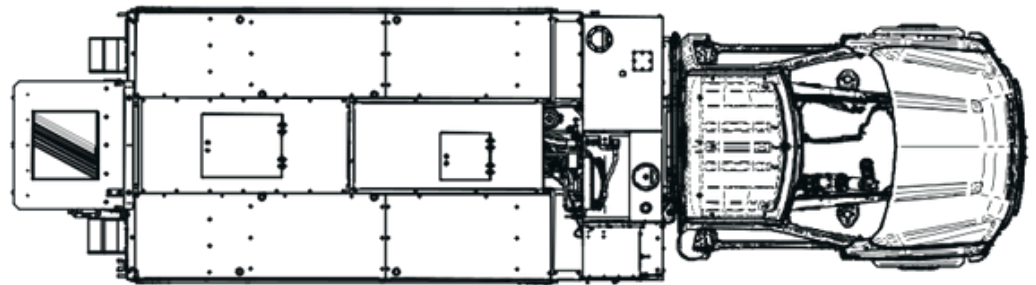

11 ft3 hopper with  
lightweight fold  
down cover

SPTO 1000  
70 yd 3 /hr

150 gallon steel  
water tank with  
water pump

SCC InCab  
controls with  
backup camera



Large decking area  
with 2 fold down side  
boards and removable  
pipe brackets

SCT2 concrete pump  
controller with wireless  
radio remote standard

# POWER BEYOND PUMPING

SCHWING

Visit [www.schwing.com/products](http://www.schwing.com/products) for more on Schwing SPTO's.

05/ 2 025



5900 Centerville Road | St. Paul, MN 55127  
1-888-SCHWING | [www.schwing.com](http://www.schwing.com)